

Specification

S-65A35-Kx/CXP-6

Adimec
Excellence in Imaging

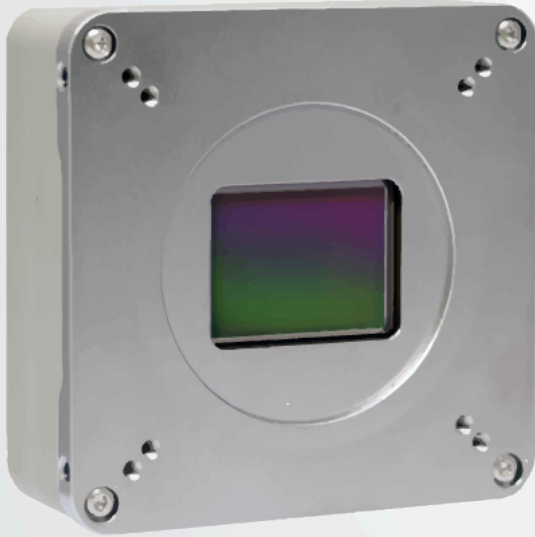

The SAPPHIRE 65 Megapixel camera delivers a superior performance in a 9344x7000 pixels resolution running at 35 fps. It uses state of the art global shutter sensor technology. The S-65A35 offers a high dynamic range with low noise levels and a high sensitivity. The camera is compatible with other CoaXPress cameras in the SAPPHIRE series: S-25 and S-50.

The S-65A35 CoaXPress camera comes in a low power, compact outline design without forced cooling through a fan. This provides optimal design freedom for system integration with maximum system reliability. The camera offers Adimec Connect & Grab™ allowing engineers to start system development.

Typical applications examples: Semiconductors metrology tools; Solar panel inspection; Medical.

CoaXPress



9344 x 7000 at 35 fps



Pixel based dark field and column based bright field uniformity correction



Low frequency flat field correction in bright



Monochrome and color



Hirose 12pin I/O connector



CoaXPress V1.1.1

Performance

Type	GPIXEL GMAX3265	
Architecture	CMOS progressive scan Global Shutter (PLS < 1/15000, angular dependent)	
Sensor diagonal	37.4 mm (29.9 x 22.4 mm)	
Pixel size	3.2 μm x 3.2 μm	
Active pixels	9344 (H) x 7000 (V)	
Microlenses	Yes	
Dynamic range	62.3 dB @ 10 bit - PGA gain 1.25*	61.5 dB @ 10 bit - PGA gain 1.25**
Full well	10.9 ke ⁻ @ PGA gain 0.75*	10.5 ke ⁻ @ PGA gain 1.25**
Dark noise	7.5 e ⁻ @ 10 bit - PGA gain 1.25*	7.4 e ⁻ @ 10 bit - PGA gain 1.25**
Sensitivity mono	67 DN ₁₀ ·cm ² /nJ @ 500 nm	

* Sensor specification, ** Typical value

Quantum Efficiency

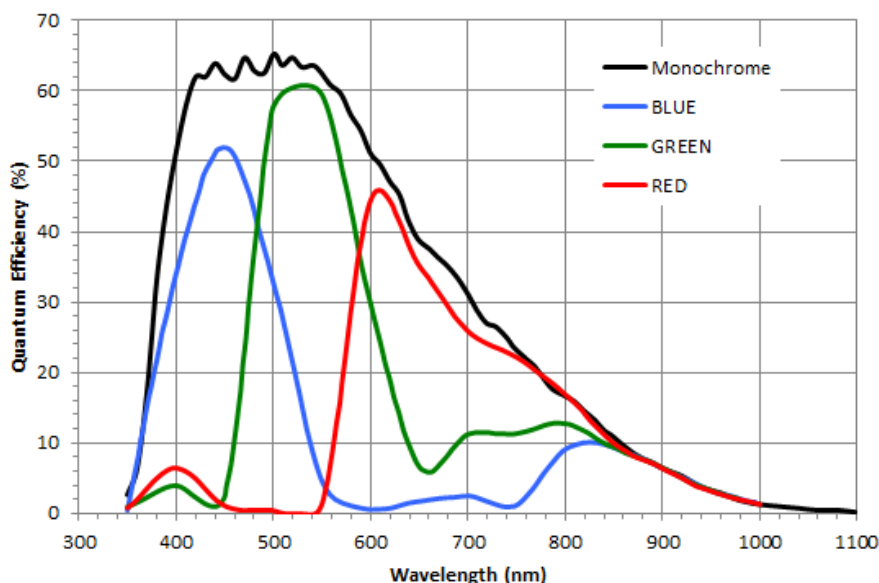

Functionality

Image acquisition	Timed, TriggerWidth, SyncControl, TimedTriggerControl
Integration time control	Programmable between 11 μs and 5 s in steps of 1 μs
Gain	Digital fine gain selectable between 1x and 32x in steps of 0.001 Programmable gain amplifier selectable between 0.75x and 6x in steps of 0.25
Video processing	Manual/One push White Balance - User programmable LUT - Gamma
Region of interest	Programmable ROI; size and position of readout image - Increased frame speed via ROI - Digital binning
Defect pixel correction	On/Off switchable - Review and editing of defect pixel map - Factory calibrated
Test mode	Internal test pattern generator available for checking of the complete digital image chain
Mirroring	The output can be reversed in the horizontal and vertical direction
Uniformity correction	Up to 50 low frequency flat field correction sets can be saved in non-volatile memory (Mono only) - Up to 14 out of 50 can be live switched from frame to frame (Mono only) User calibratable pixel based dark field (DSNU) and column based bright field uniformity correction
Sensitivity Matching	Conversion gain calibrated per camera to achieve sensitivity matching between cameras
Miscellaneous functions	Programmable I/O polarity with deglitch function - 1 factory set and 10 user sets for storage of camera settings - Frame counter - Temperature readout - Camera type, build state and serial number can be read via software

Interfacing

Video

Video output	CoaXPress V1.1.1 CXP3/6 1, 2, 4 lanes configurable
External Sync	I/O or CXP controlled
Output resolution	8 / 10 / 12 bit
Connector	4 x DIN1.0/2.3

Camera Control Protocol

Interface	GenICam via CoaXPress
Throughput	20 Mbps
Protocol	GenTL

I/O

Output	LVDS - Fully programmable flash strobe signal (duration, delay and polarity)
Input	LVDS - Trigger signal with programmable polarity
Connector	Hirose 12 pin HR10A-10R-12P(73)

Power

Input voltage	24 VDC PoCXP
Power dissipation	< 13 W @ 24 VDC full continuous operation at maximal framespeed
Power connector	DIN1.0/2.3 CoaXPress Masterlink

Interface connectors

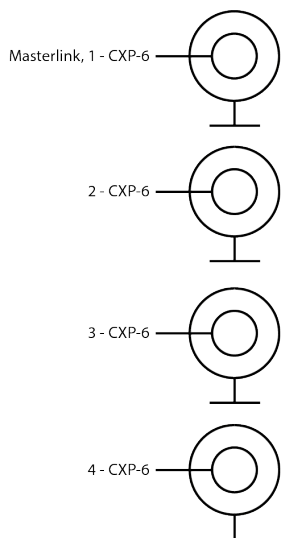

Figure 1. Quad CXP DIN1.0/2.3

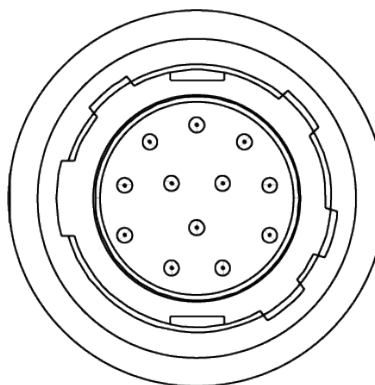

Figure 2. Hirose 12 pin HR10A-10R-12P(73) I/O connector

High Resolution Metrology Camera

Mechanical

Mounting	2 x M4 mounting holes per side on camera front
Lensmount	4 x M3 at 60mm pitch - 4 x M3 at 54mm pitch - 50mm G7 reference (on request: F, TFL-II, T2, M42)
Heatsink	4 x M3 at 70mm pitch on camera backplate (on request: Heatsink available)
Outline	See figure
Weight	400 g +/- 5% excl. lensmount and heatsink

Mechanical outline

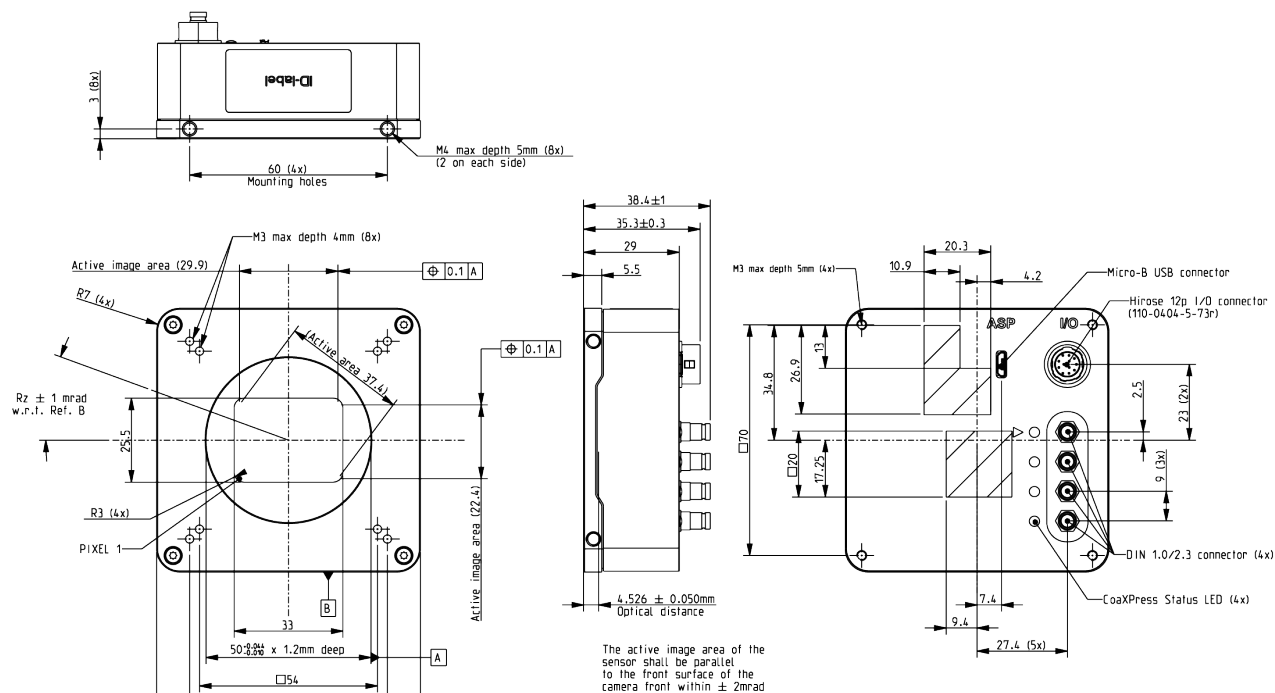

Sensor Mounting Accuracy

XY-centering	± 0.050 mm
Rotation	± 1 mRad
Optical distance	4.526 ± 0.050 mm
Perpendicularity	± 2 mRad

Compliance & Reliability

RoHS

Directive	RoHS directive 2011/65/EU (incl. amendment 2015/863)
-----------	--

CE-mark

Electromagnetic compatibility	2014/30/EU: EN61000-6-3 and EN61000-6-2
ESD	Contact discharge +/- 4 kV; Air discharge +/- 8 kV
Workmanship	In accordance with IPC-J-STD-001 class 2 and inspected according IPC-A-610 class 2

Reliability

MTBF	> 75,000h @ 30 °C calculated according to the part stress analysis of MIL-HDBK-217F for ground fixed, uncontrolled environment.
------	---

High Resolution Metrology Camera

Environmental

Operating

Sensor temperature	+5°C to +70°C
Humidity (relative)	20% - 80% non-condensing
Shock	10 g, half sine shape, 6-10ms duration in $\pm X$, $\pm Y$ and $\pm Z$
Vibration	3 g sinusoidal vibration sweeps 5 - 150 Hz

Storage

Temperature	-25°C to +65°C
Humidity (relative)	5% - 95% non-condensing
Shock	25 g, half sine shape, 6-10 ms duration in $\pm X$, $\pm Y$ and $\pm Z$
Vibration	10 g sinusoidal vibration sweeps 5 - 150 Hz

Camera Types

Camera	Interface connector	I/O connector	Sensor	Type	Max. fps @ Full resolution
S-65A35-Km/CXP-6-1.0	4 x DIN1.0/2.3	Hirose 12 pin	GMAX3265 (monochrome)	Monochrome	35 fps
S-65A35-Kc/CXP-6-1.0	4 x DIN1.0/2.3	Hirose 12 pin	GMAX3265 (color)	Raw Bayer	35 fps

Adimec

Adimec is the leading supplier of high-end cameras for machine vision, medical and outdoor imaging applications. Our Adimec True Accurate Imaging® technology forms the foundation for a broad range of camera products, and brings new levels of precision and accuracy to vision systems.

Custom cameras

Adimec has the ability to offer additional camera functionality and create customer specific cameras even for small volume programs. Built from platforms, our standard line of cameras give us a flexible base that can be tailored to fit your specifications. Contact us to discuss these options in more detail. Visit: www.adimec.com for product details.



For maximum image quality, performance, and reliability in demanding applications - Choose Adimec

North America	Europe	Japan & Korea	Asia - Pacific	China
Phone: (+1)-781-279-0770	(+31)-40-2353900	(+81)3-5968-8377	(+65)-6334-1236	(+86)21-6266-1692
Fax: (+1)-781-279-0771	-	(+81)3-5968-8388	(+65)-6334-1436	-
E-mail: salesus@adimec.com	saleseu@adimec.com	salesjp@adimec.com	salesap@adimec.com	salescn@adimec.com.cn

Detailed information on request - Subject to change without notice - Actual products may differ from photos
S-65A35-Kx/CXP-6 Revision 1.0

Adimec
www.adimec.com